

HiCOETS2

**PC/104 Ethernet Controller
with two serial Ports**

**HiCOETS2-DOC
User Manual**

Copyright

emtrion

30.80.0200.0

© Copyright 2008 emtrion GmbH

All rights reserved. Without written consent, this documentation may neither be copied nor saved to electronic media. The information contained in this documentation may be changed without notice. We are not liable for incorrect information and their consequences. The used trademarks of other companies label exclusively the products of those companies.

Manual Revision no.	Changes	Date
1	First edition	09-30-99/ Bue
2	Revision and translation	06-06-00/ Bue-Re
3	Emtrion edition	02-06-04/ Ma
4	Information about baudrate clock added in chapter 4.1	21-11-06/ Bue
5	Pdf Data file setting changed	20-05-2008/ Ma

The user manual is published by:

This document is published by:

emtrion GmbH

Greschbachstr. 12

D-76229 Karlsruhe

<http://www.emtrion.de>

Tel: +49 721 62725-20

Fax: +49 721 62725-19

E-mail: <mailto:mail@emtrion.de>

November 2008 - 005

Table of Contents

1.	Overview	4
1.1.	Introduction	4
1.2.	Key Features of the HiCOETS2 Module	4
2.	Installing HiCOETS2	5
3.	Ethernet Controller	5
3.1.	General Information.....	5
3.2.	Configuring the Ethernet Controller	6
3.3.	Programming the EEPROM	6
3.4.	Diagnostic LEDs.....	6
3.5.	Drivers	7
3.6.	Ethernet Cable	7
4.	Serial Ports	8
4.1.	General Information.....	8
4.2.	Address Setting.....	9
4.3.	Interrupt Setting.....	10
4.4.	Serial Port Channel A.....	10
4.5.	Serial Port Channel B.....	10
4.5.1.	Channel B as RS232 Interface.....	10
4.5.2.	Channel B as RS485 Interface.....	11
5.	Boot-PROM Socket	13
6.	Jumpers W1 and W2, Solder Bridge LB1	14
6.1.	Solder Bridge Assignment.....	14
6.2.	Position of the Bridges and Jumpers.....	14
7.	Pin Assignment	15
7.1.	J1, PC/104.....	15
7.2.	J3, Ethernet 10 Base-T	16
7.3.	J4, Ethernet 10 Base-T	16
7.4.	J5, Ethernet AUI	17
7.5.	J6, Serial Port Channel A, RS232	17
7.6.	J7, Serial Port Channel B, RS232	17
7.7.	J7, Serial Port Channel B, RS485	18
8.	Dimensional Drawing	18
9.	Technical Data	19
9.1.	Mechanical Data.....	19
9.2.	Electrical Data	19
9.2.1.	Supply Voltage	19
9.3.	Environmental Conditions	19
10.	Web Reference	19

1. Overview

1.1. Introduction

HiCOETS2 is a communications module with Ethernet controller in accordance with IEEE 802.3 and two asynchronous serial interfaces. The connection to the Ethernet network is either directly via 10Base-T or via an AUI (attachment unit interface) with external MAU (media access unit). The serial ports come with 16-byte FIFOs and comply with the PC standard 16550. In addition, a 32-pin socket is mounted to accommodate a boot PROM or silicon disk.

This manual is addressed to Original Equipment Manufacturers (OEM) who wish to customize the HiCOETS2 module for their particular projects. It provides information and tips on both installation and configuration of the module.

1.2. Key Features of the HiCOETS2 Module

Feature	Function
Ethernet controller	RTL8019AS
Data rate	10 Mbps
Compatibility	NE2000, IEEE 802.3
Interface	10Base-T, AUI
Remote boot	possible via 32-pin socket
DUART	ST16C552
Interface	1 x RS232, 1 x RS232/RS485
Socket	Boot PROM or silicon disk
Bus interface	PC/104, 8 or 16 bits
Power supply	+5V, 0.2A
Operating temperature	0°C to +70°C
Storage temperature	-40°C to +125°C
Dimensions	96 mm x 90 mm x 20 mm

2. Installing HiCOETS2

Please read the following notes prior to installing the HiCOETS2 module. They apply to all ESD (electrostatic discharge) components:

- Before installing the module, it is recommended that you discharge yourself by touching a grounded object.
- Be sure all tools required for installation are electrostatically discharged as well.
- Before installing (or removing) the board, remove the power cable from your mains supply.
- Handle the board with care and try to avoid touching its components or tracks.

HiCOETS2 is a CPU PC/104 module which may only be operated in a PC/104 environment along with a PC. When installing the board, care must be taken of the following:

- Make sure all jumpers are properly set.
- Connect HiCOETS2 to the other components via the 104-contact J1 connector. Four fastening screws are provided to fix the board.
- HiCOETS2 requires only +5V when using the 10Base-T connection. Additional +12 volts are required if you wish to connect an MAU to the AUI interface J5.
- HiCOETS2 is shipped in a conductive packaging. The soldered battery is protected with scotch tape against discharge during shipping. This tape can now be removed.

3. Ethernet Controller

3.1. General Information

HiCOETS2 is based on the powerful Realtek RTL8019AS Ethernet controller. This controller complies with the Ethernet standard IEEE 802.3 with CSMA/CD protocol at a transfer rate of 10 Mbps.

Both hardware and drivers are fully compatible with the Novell NE2000 standard. The controller provides a 16-Kbyte SRAM as message buffer.

The controller may be operated with an 8-bit or 16-bit ISA bus. The data width is recognized automatically. The bus interface may either be used as a Plug and Play interface or configured via software.

The module provides a 10Base-T connector via an RJ-45 jack and a 16-pin AUI connector for the connection of an external MAU. The two interfaces are electrically isolated from the controller. For easy mounting, the signals of the RJ-45 jack are additionally applied to a 10-pin connector, allowing for front panel connection.

Two LEDs indicate that a cable has been connected to the RJ-45 jack and that data transfer takes place on a connected Ethernet cable.

A 32-pin socket serves to accommodate a boot PROM, which allows for booting a PC without mass storage via the Ethernet.

3.2. Configuring the Ethernet Controller

The supplied CD-ROM contains a DOS program called RSET8019.EXE. This program serves to configure and test the Ethernet controller.

RSET8019.EXE provides the following:

- Display of the current configuration
- Definition of a new configuration
- Functional test of the Ethernet controller

The connection should always be set to "Auto Detect". The module will then automatically detect the connection in use.

The settings for the boot ROM are of no significance. The socket installed in the HiCOETS2 is not selected by the Ethernet controller. The entry for Boot ROM should always be set to "No Boot ROM"; otherwise the Ethernet controller uses the memory region entered.

3.3. Programming the EEPROM

The Ethernet controller's setup data are contained within an EEPROM. If these contents are lost, new default data may be programmed into the EEPROM using the PG8019.EXE program. For this, PG8019.EXE enters the data of the 8019AS.CFG file into the EEPROM.

Note

When programming the EEPROM, a dummy network board number is entered. This number is not unambiguous and should only be used in a company's internal LAN. If you wish to program a permitted board number, contact us.

3.4. Diagnostic LEDs

To indicate the status of the Ethernet connection, HiCOETS2 provides two LEDs.

The green LED goes on to indicate that data are being transferred. During normal operation, this green LED blinks at irregular intervals.

The red LED goes on to indicate data collisions on the cable. During normal operation, the red LED does not light up.

3.5. Drivers

HiCOETS2 is fully NE2000 compatible. This standard is used by most operating systems as a generic configuration without drivers.

In addition, the supplied CD-ROM provides several drivers for the following:

- Netware ODI
- NDIS 2.x
- Windows 9x
- Windows NT 3.5, 4.0
- OS/2
- Lantastic 4.x, 5.x, 6.x
- Packet driver
- SCO Unix
- Linux

The current drivers can be found on the internet at:

<http://www.realtek.com.tw>

3.6. Ethernet Cable

The following cables are specified for a data rate of 10 Mbps:

Ethernet type	Topology	Cable type	Segment length
10Base-2	Bus	Coax 50 Ω , Ethernet thin, RG-58	max. 185 m
10Base-5	Bus	Coax 50 Ω , Ethernet thick, RG-11	max. 500 m
10Base-T	Star	Unshielded Twisted Pair, 100 Ω	max. 100 m

For the 10Base-2 and 10Base-5 connection, an external MAU is required.

4. Serial Ports

4.1. General Information

HiCOETS2 has two serial ports. They are PC-compatible and provide FIFOs in accordance with NS16C550.

Each port can be set to one of 16 possible addresses via a wiper switch, and utilize one of 4 possible interrupts. In addition to the standard values for COM1 ... COM4, 12 further addresses, which are not specified for COM ports, are possible. In addition to the interrupts IRQ3 and IRQ4 for COM1 and COM2, the interrupts IRQ10 and IRQ12 are allowed. Note, however, that the interrupts are not used more than once.









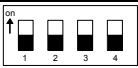

The baud rate can be set from 56 baud to 115 KBaud. The input clock of the UARTs is 1.8432 MHz which is the standard clock used in PCs. With a divider setting of 1 you get the maximum baud rate 115 KBaud.

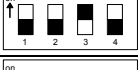
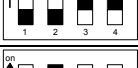
If the interrupts IRQ10 and IRQ12 are not used, the serial ports may be operated on both an 8-bit and 16-bit ISA bus. The interrupts IRQ10 and IRQ12 are only available with a 16-bit bus.

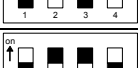
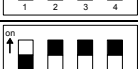
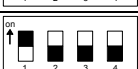
In the following, the two interfaces are designated port A and B. Port A is specified as an RS232 interface. Port B may either be used as an RS232- or RS485 interface. No special drivers are required. More details on the programming of the interface can be found under [2].

4.2. Address Setting

The addresses of the COM ports are set via the switches S1 and S3. The assignment is as follows:

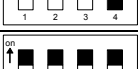
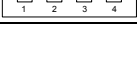
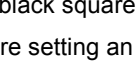
DIP Switch	Address	Use
	3F8h	COM1
	3E8h	COM3
	3D8h	VGA controller
	3C8h	VGA controller
	378h	LPT1
	368h	free
	358h	free
	348h	free
	2F8h	COM2
	2E8h	COM4
	2D8h	free
	2C8h	free
	278h	free
	268h	free
	258h	free
	248h	free





The black square indicates the respective position of the switch.

Before setting an address, make sure the addresses are not used by other functions.

If the same address is defined for channel A and channel B, channel B will be automatically disabled.

4.3. Interrupt Setting

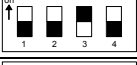
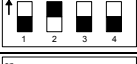
The interrupts of the COM ports are defined using the switches S2 and S4. The following setting applies:

DIP Switch	Interrupt	Use
	none	-
	12	PS/2 mouse
	10	-
	4	COM1
	3	COM2

The black square indicates the respective position of the switch.

Before setting an address, make sure the addresses are not used by other functions.

Max. one switch per channel may be set to "on".

4.4. Serial Port Channel A

The serial port channel A is implemented with drivers according to RS232. It provides 16-byte receive and transmit data FIFOs and is 16C550-compatible.

The port is connected to the 10-pin header J6. The address setting is via the S3 switch, the interrupts are set with the S2 switch.

4.5. Serial Port Channel B

The serial interface channel B may either be defined as an RS485- or RS232 interface. It provides 16-byte deep receive and transmit FIFOs and is 16C550-compatible.

The port is connected to the 10-pin header J7. The address setting is via the S1 switch, the interrupt setting via the S4 switch.

By default, the port is set according to RS485.

4.5.1. Channel B as RS232 Interface

If solder bridge LB1 is closed, channel B functions as an RS232 interface. In addition to the data lines RxD and TxD, the handshake signals RTS and CTS are available on the J7 connector. The signals DTR, DSR and DCD are locally bridged and not connected to the connector.

The jumpers W1 and W2 are of no significance in this case.

4.5.2. Channel B as RS485 Interface

If the solder bridge LB1 is open, channel B functions as an RS485 interface. The transmit lines TxD+ and TxD- and the receive lines RxD+ and RxD- are separately connected to the J7 connector. The signals RTS, CTS and DTR, DSR, DCD are locally bridged each and not connected to the connector.

Transmitter and receiver of the RS485 interface can be enabled or disabled via the modem signals RTS and DTR. The RS485 transmitter is always enabled with RTS = 1. The transmitter is enabled with the W1 jumper. The following applies:

Position W1	Function
1	Transmitter is enabled with DTR = 1
2	Receiver is enabled with RTS = 0

If the jumper is set to 1, the receiver is enabled regardless of the transmitter's state. If the jumper is set to 2, the receiver is enabled when disabling the transmitter. If you connect the signals RxD+ with TxD+ and RxD- with TxD- at the connector, setting the jumper to position 2 will prevent the port itself from transmitting.







Together with the W2 jumper a 120-Ω terminal resistor is installed between RxD+ and RxD-. This resistor is required to attenuate noise with long lines.

Position W2	Function
on	Resistor is connected.
off	Resistor is not connected.

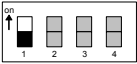
5. Boot-PROM Socket

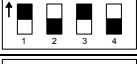
The 32-pin socket serves to accommodate a Boot PROM or a flash disk DiskOnChip® 2000 from M-Systems [4].

The socket's address space is 16KB, the base address can be set via the S5 switches in steps of 16KB. If switch 1 of S5 is set to "off", the socket is not activated. The following address setting applies:

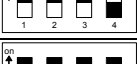
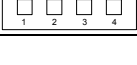
DIP Switch	Address region
	disabled
	DC000 – DFFFF
	D8000 – DBFFF
	D4000 – D7FFF
	D0000 – D3FFF
	CC000 – CFFFF
	C8000 – CBFFF
	C4000 – C7FFF
	C0000 – C3FFF

The black square indicates the respective position of the switch.

You are able to install the EPROM types 27C512 or 27C010 in the socket. However, only the lower 16K bytes of the PROM are accessed. For a remote boot via Ethernet, the necessary binary files for boot PROM are also available. These files can be found on the supplied CD in the drivers directory.

The socket may also accommodate an integrated flash disk DiskOnChip® 2000 from M-Systems. Bootable flash disks with a capacity from 2 MB to 144 MB can be ordered at emtrion (ordering code: HiCO486-Fxx).

6. Jumpers W1 and W2, Solder Bridge LB1

6.1. Solder Bridge Assignment

HiCOETS2 provides two jumpers and a solder bridge. Solder bridge LB1 is used to switch the serial port channel B between the RS232 and RS485 mode. In the RS485 operating mode, the receiver is enabled with W1. W2 can be used to connect a 120-Ω terminal resistor between the inputs RXD+ and RXD- of the receiver. The jumpers are of no significance in the RS232 mode.

Bridge	Position	Function
LB1	open	Channel B is RS485
	closed	Channel B is RS232

W1	1	Receiver enabled with DTR
	2	Receiver enabled with RTS
W2	on	Terminal resistor activated with 120 Ω
	off	Terminal resistor deactivated with 120 Ω

6.2. Position of the Bridges and Jumpers

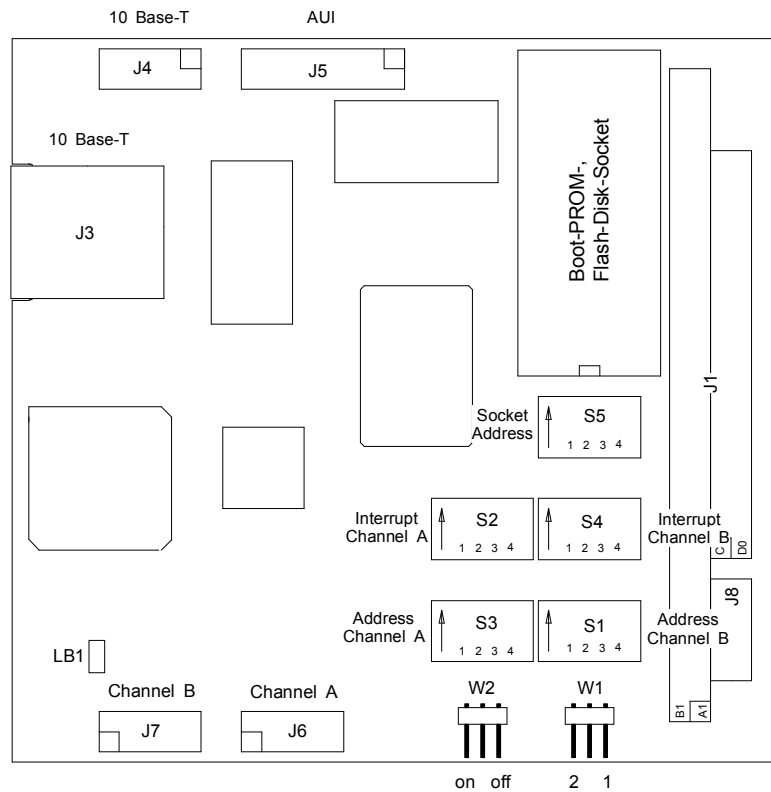

7. Pin Assignment

7.1. J1, PC/104

Type 64-pin + 40-pin header with long pins, 2.54 mm

	Row A	Row B	Row C	Row D	
1	-	GND			
2	D7	RESET			
3	D6	+5 V			
4	D5	IRQ9			
5	D4	-			
6	D3	-			
7	D2	-			
8	D1	-			
9	D0	+12 V	GND	GND	0
10	IOCHRDY	-	-	-	1
11	AEN	SMEMW#	-	IOCS16#	2
12	A19	SMEMR#	-	IRQ10	3
13	A18	IOW#	-	IRQ11	4
14	A17	IOR#	-	IRQ12	5
15	A16	-	-	IRQ15	6
16	A15	-	-	-	7
17	A14	-	-	-	8
18	A13	-	-	-	9
19	A12	-	-	-	10
20	A11	-	D8	-	11
21	A10	-	D9	-	12
22	A9	-	D10	-	13
23	A8	IRQ5	D11	-	14
24	A7	IRQ4	D12	-	15
25	A6	IRQ3	D13	+5 V	16
26	A5	-	D14	-	17
27	A4	-	D15	GND	18
28	A3	-	-	GND	19
29	A2	+5 V			
30	A1	-			
31	A0	GND			
32	GND	GND			

7.2. J3, Ethernet 10 Base-T

Type RJ45

Pin	Signal
1	TD+
2	TD-
3	RD+
4	-
5	-
6	RD-
7	-
8	-

7.3. J4, Ethernet 10 Base-T

Type 10-pin connector, 2.54 mm

Pin	Signal	Pin	Signal
1	AUI +5V	2	LED2-
3	RD+	4	RD-
5	LED1-	6	GND
7	-	8	GND
9	TD+	10	TD-

You are able to connect low-current LEDs, which draw 2 mA from +5V to the signals LED1- and LED2-. LED1- indicates the data transfer. LED2- indicates data collisions.

7.4. J5, Ethernet AUI

Type 16-pin connector, 2.54 mm

Pin	Signal	Pin	Signal
1	GND	2	CD-
3	CD+	4	TX-
5	TX+	6	GND
7	GND	8	RX-
9	RX+	10	AUI +12V
11	GND	12	GND
13	-	14	-
15	-	16	AUI +5V

7.5. J6, Serial Port Channel A, RS232

Type 10-pin connector, angled, 2.54 mm

Pin	Signal	Pin	Signal
1	DCD	2	DSR
3	RxD	4	RTS
5	TxD	6	CTS
7	DTR	8	RI
9	GND	10	+5V

7.6. J7, Serial Port Channel B, RS232

Type 10-pin connector, angled, 2.54 mm

Pin	Signal	Pin	Signal
1	nu	2	nu
3	RxD	4	RTS
5	TxD	6	CTS
7	nu	8	nu
9	GND	10	+5V

nu: DO NOT CONNECT with RS232 !

7.7. J7, Serial Port Channel B, RS485

Type 10-pin connector, angled, 2.54 mm

Pin	Signal	Pin	Signal
1	RXD+	2	RXD-
3	nu	4	nu
5	nu	6	nu
7	TXD+	8	TXD-
9	GND	10	+5V

nu: DO NOT CONNECT with RS485 !

8. Dimensional Drawing

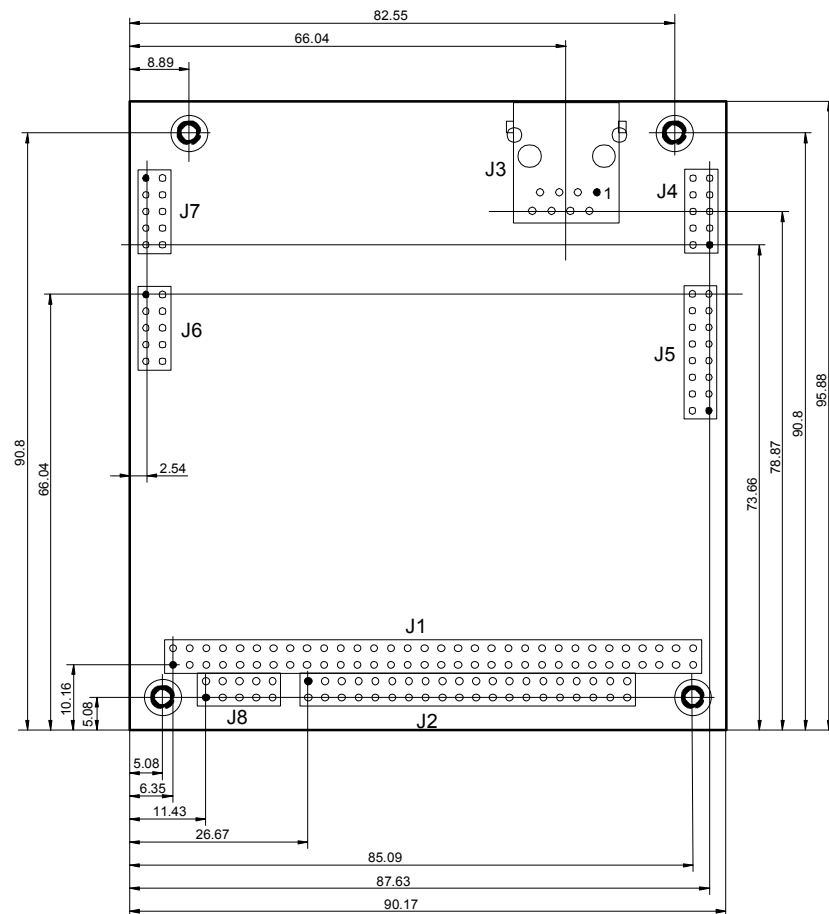

9. Technical Data

9.1. Mechanical Data

Weight	73 g
Board	Glasepoxi FR-4, UL listed, 10 layers
Dimensions	96 mm x 90 mm x 22 mm

9.2. Electrical Data

9.2.1. Supply Voltage

Supply voltage	5V, +/-5%
Power consumption	0.2 A typ.

9.3. Environmental Conditions

Temperature	0 ... +70°C during operation -40 ... +125°C storage
Rel. humidity	0 ... 95 %, non-condensing

10. Web Reference

- [1] RTL8019
Relate Full-Duplex Ethernet Controller with Plug and Play Function
Advance Information, April 1995
Relate Seem-Conductor Co., LTD.
<http://www.realtek.com.tw>

- [2] ST16C2552 Dual UART with 16-Byte Transmit and Receive FIFOs
Datasheet, Revision 3.5, 1990
Ear Corporation,
<http://www.exar.com/products/st16c2552.html>

- [3] DiskOnChip®2000
Product Manual, Revision 2.0
M-Systems Inc.,
<http://www.m-sys.com/>

- [4] PC/104 Specification
Version 2.3, June 1996
<http://www.controlled.com/pc104/techp1.html>