

HiCO.CAN-CPCI CAN Interface for Compact PCI



- Electrical isolation via 82C251 ISO/DIS driver; SJA1000 CAN controller
- 2 CAN interfaces,
- 68332G processor, 20 MHz
- 2-Kbyte DPM Interface
- Up to 1 Mbaud at 100% busload
- Supports CAN 2.0A and CAN 2.0B, CANopen
- Interrupts and base address controlled via PCI controller
- Timestamps with 10-us resolution
- Driver for DOS, Linux, Windows® 9x, Windows® NT 4.0, Windows XP

Order Codes:

- HiCO.CAN-CPCI-2 Compact PCI CAN-Interface, 2 CAN-Schnittstellen
- HiCO.CAN-CPCI-1 Compact PCI CAN-Interface, 1 CAN-Schnittstelle
- HiCO.CAN-SW Software und Dokumentation für den CAN-Bus



Main Office Germany

Greschbachstraße 12
D-76229 Karlsruhe
Tel. +49 (721) 62725-0
Fax +49 (721) 62725-19
eMail: sales@emtrion.com
Visit us on the internet!
www.emtrion.com

32-Bit Performance

HiCO.CAN-CPCI comes with a 68332 microcontroller with 20 MHz. This 32-bit wide controller is able to handle the CAN messages of two nodes at a bus speed of 1 Mbaud each. HiCO.CAN-CPCI provides a 512-kByte flash and 128-kByte SRAM both to forward the data and implement customer-specific applications. A serial interface (RS232) is reserved for customer applications.

CAN Layers

The physical layer is in accordance with the ISO11898 standard. The two CAN buses are electrically isolated via optocouplers. Voltage is supplied by the integrated DC/DC converters (standard) or can be applied externally. All baud rates up to 1 Mbaud are supported.

The layer-2 implementation contains Basic (2.0A) and Extended (2.0B) CAN. As CAN controller the SJA1000 is used. The layer-2 firmware supports operation in PeliCAN mode. In the PeliCAN mode mixed traffic of Basic and Extended CAN messages is possible. The CAN open implementation of the firmware will comply with the DS 301 standard set by the CiA group.

Application Interface

The application interface supports DOS, Linux, Windows 9x/ME/2000/XP and Windows NT 4.0. In addition, it may easily be adapted to other operating systems. The supplied libraries for 32-bit applications provide simple functions for both controlling the module and for receiving and transmitting messages. With reads timestamps are available.

The libraries contain additional functions for polling the module's state and temporarily modifying the CAN parameters. Communication between the driver layer on the PC and the firmware is via fast FIFOs in the DPM. For this, interrupts are used to ensure that the messages received or transmitted are processed in real time.

The location of the DPM and the interrupt levels in the PC is controlled via PCI controller. In addition, software for specifying the user-defined parameters is supplied.

Customer-Specific Configuration

HiCO.CAN-CPCI can be configured to your liking. For example, DC/DC converters might not be required, or you may wish to use one CAN node only; please contact us. We provide you with the HiCO.CAN-CPCI you need to meet your specific design challenges.

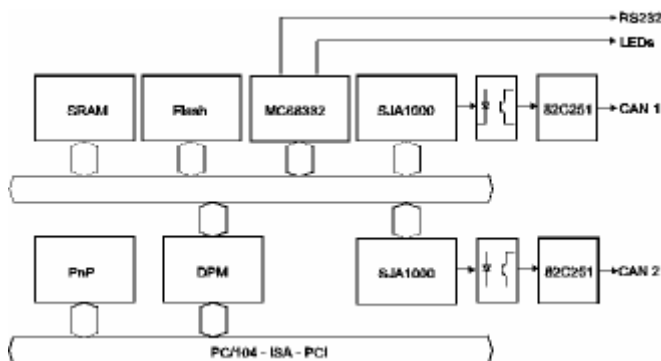

HiCO.CAN-CPCI is also available as a module (HiCOCAN-104) for the PC/104 bus, for the PCI Bus and for the ISA Bus of PC.



Main Office Germany

Greschbachstraße 12
D-76229 Karlsruhe
Tel. +49 (721) 62725-0
Fax +49 (721) 62725-19
eMail: sales@emtrion.com
Visit us on the internet!
www.emtrion.com